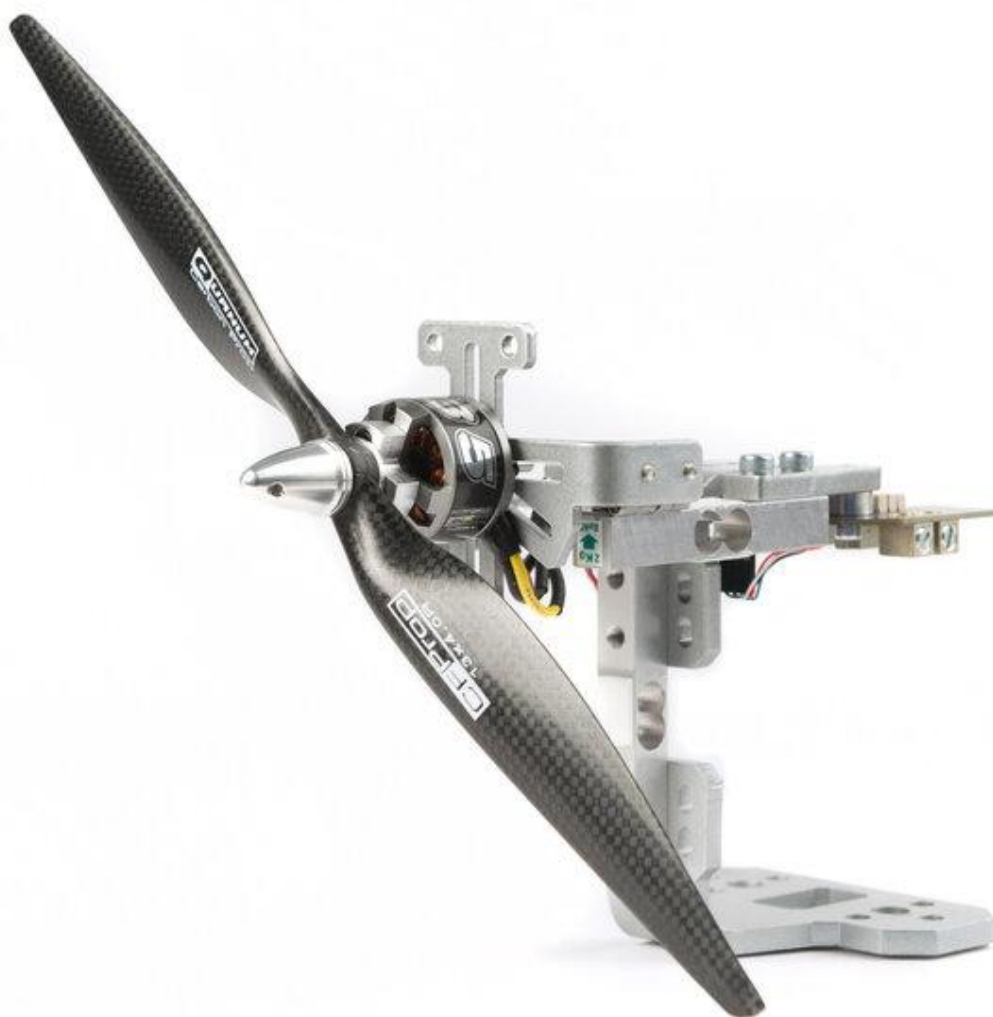




---

## Series 1585 Thrust Stand Datasheet

---



## Introduction

The RCbenchmark Series 1585 Test Stand is designed to greatly reduce the time required for characterizing, testing, and designing brushless motor propulsion systems, while obtaining precise and accurate results. It is the updated version of the Series 1580, and provides a higher load measurement sample rate, higher power measurement capacity, and better electrostatic discharge (ESD) protection.

## Description

The Series 1585 Test Stand was specifically developed to allow drone designers to improve the efficiency of their propulsion systems. The test stand connects to your computer via USB and uses powerful software for automated control and data-logging. The ESC can be controlled manually or with custom scripts using the scripting interface.

Motor and propeller data can be viewed in real-time then exported to a .CSV file once tests are complete. Multiple accessories are available to help UAV developers further characterize their aircraft and achieve peak performance. It is the ideal tool for optimizing the performances of drones, robots and radio-controlled vehicles.

### Direct measurements

- Torque (Nm)
- Thrust (kgf)
- Voltage (V) and current (A)
- Rotations per minute (RPM)
- Motor winding resistance (Ohm)
- Accelerometer on PCB (g)

### Derived measurements

- Motor efficiency (%)
- Propeller efficiency (g/W)

- USB interface
- ESC manual control
- Three servo control ports
- Automatic control
- Powerful scripting
- Three accessory ports
- Three temperature probe ports
- Output data to CSV file
- Real-time sensor plots
- Included calibration hardware

## Applications

- Inrunner and outrunner brushless motor characterization (0~55 A)
- Propeller characterization
- Calculate system efficiency
- Servo testing and control
- Battery endurance testing
- Factory tests

## Technical Specifications

**Table 1:** Design specifications of the Series 1585 Test Stand

Specification	Min.	Max.	Tolerance	Unit
Thrust	-5	5	0.5%±0.001	kgf
Torque	-2	2	0.5%±0.001	Nm
Voltage	0	50	0.5%	V
Current	0	55	1%	A
Burst Current	0	60		A
Angular speed*	0	190k	1	eRPM
Coil resistance	0.003	240	0.5%	Ohm
Digital scale	0	3	0.5%	kgf

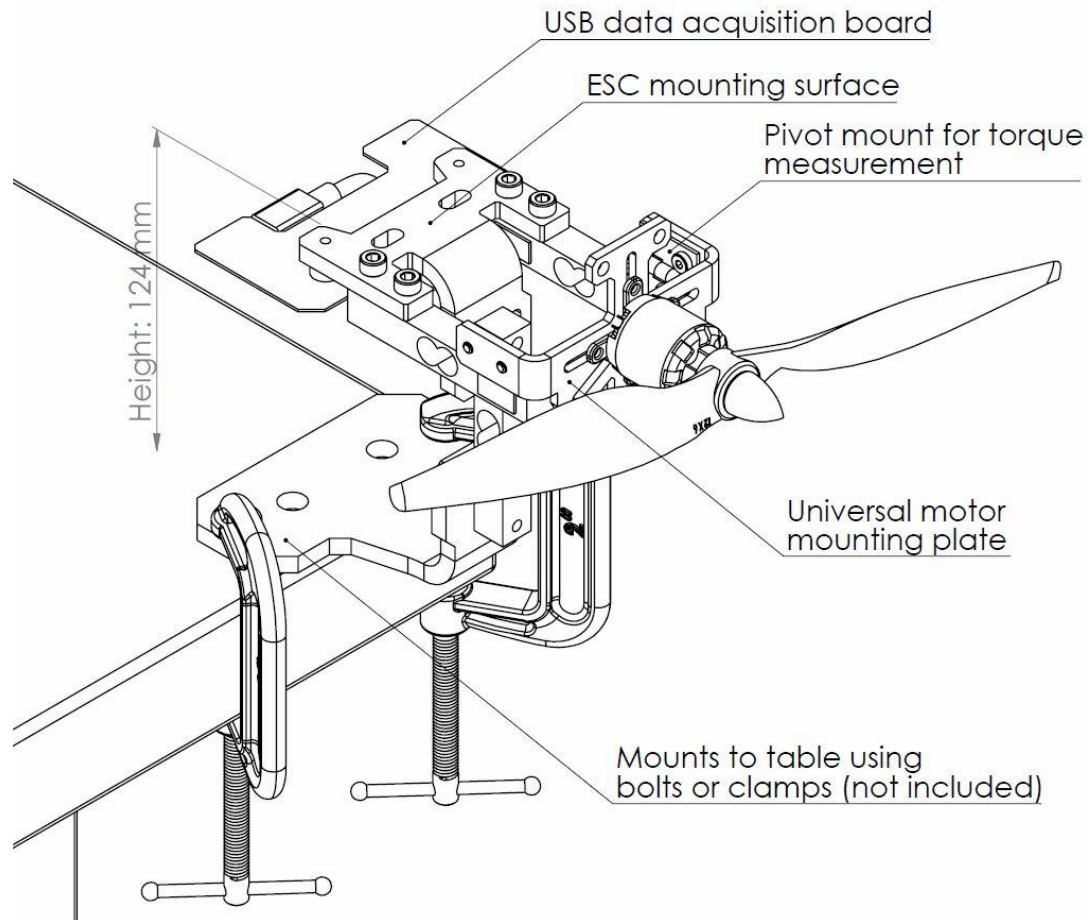
\*Electrical RPM, divide by the number of motor poles to obtain true mechanical RPM.

The sampling rate is determined by your computer (up to ~80 Hz). The torque measurement accuracy is valid for tools produced after 2020-01, or for tools using the rigid sheet metal connector between the motor mount and the load cells. The previous design using hinges had 0.5%±0.01 Nm accuracy.

Your test accuracy depends on your experimental setup. Loose wires and objects in the test area will affect the accuracy due to the ground effect of the propeller.

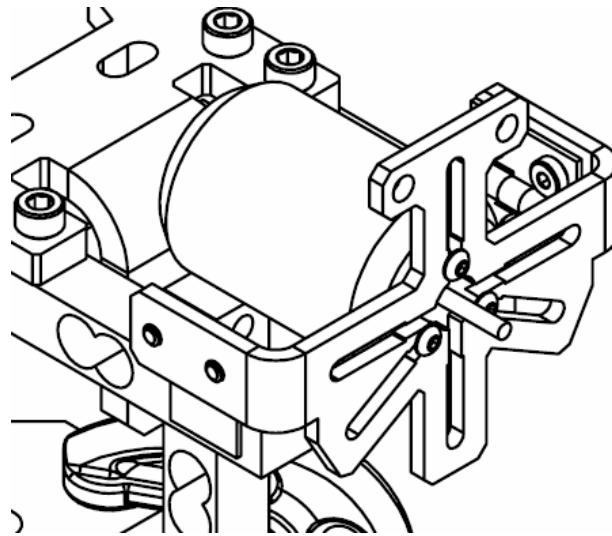
## Hardware

The Series 1585 Test Stand is designed to measure essential motor and propeller performance metrics. Figure 1 shows an overview of the important components of the tool.

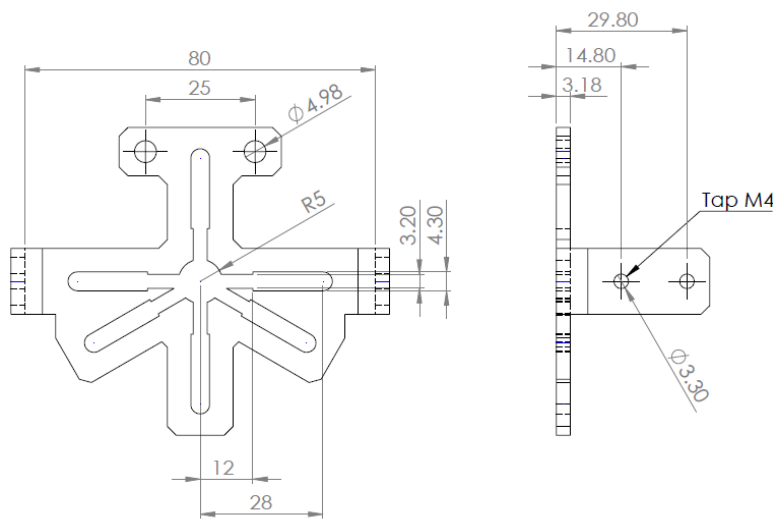


**Fig. 1:** Hardware overview

For a given **voltage**, brushless motor **speed** is a function of two variables: the **mechanical load** (in Nm), and the **electrical signal input** (which can be measured in duty cycle or percentage of the maximum command sent to the ESC). The motors are characterized by changing the input from the software and by changing the load with multiple propellers. The load changes as propellers have different size and pitch.



**Fig. 2:** Mounting shown with 36 mm  $\varnothing$  and 53 mm length inrunner motor.



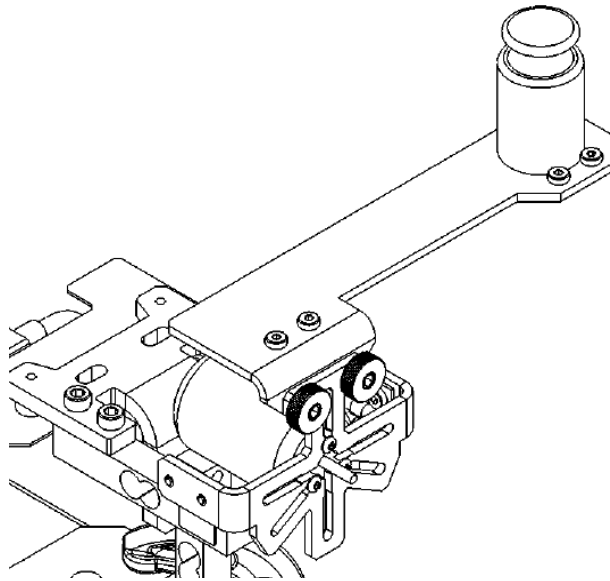
**Fig. 3:** Motor mounting part dimensions

The test device can accept most inrunner and outrunner brushless motors with M2 to M4 screws and screw spacing of up to 56 mm. Inrunner motors can have a maximum length of 55 mm and a maximum diameter of 48 mm. Figure 2 shows an example of an inrunner mounted on the device.

Use the drawing in Figure 3 to check if you can install your motor on the device. The pattern fits almost all standard medium-size motors. Otherwise, you can make a wood adapter, or design your own motor mounting part using the dimensions in the drawing.

## Calibration

The test stand comes with hardware for calibrating the torque and thrust measurements. Figure 5 shows the device with its included calibration hardware and precision weight. See the instruction in the RCbenchmark GUI for detailed calibration instructions.



**Fig. 5:** Calibration hardware (included)

## Circuit Board (PCB)

The Series 1585 circuit board is designed for the Series 1585 Test Stand, compatible with the RCbenchmark GUI. Compared with the Series 1580 circuit board, it has better ESD protection, higher power capacity, and a higher sampling rate for the force sensor (up to 80 Hz).

The circuit board is able to measure three load cell units, ESC power, RPM of the motor acceleration and winding resistor of the motor. It is compatible with three temperature probes, one optical RPM probe and three I2C interface accessories (from Tyto Robotics). Please find information on the accessories on the next page.

The circuit provides a 5V power selector to the operator. When the user needs to power the ESC or the optical RPM probe, please put the jumper on the headers. When testing the servo motor, unplug the jumper and use your own power supply. The maximum current output of the on-board 5 V power supply is 100 mA. Inappropriate operation can damage the circuit.

## Accessories

The Serial 1585 Test Stand has several optional accessories. For the purchase information, please visit our [online store](#).

1. Airspeed Probe / Pressure Sensor for Airspeed Measurement

The airspeed probe is a precision differential pressure sensor fully integrated with the RCbenchmark software. The sensor is intended to be used with a pitot tube to measure the airspeed in a wind tunnel or the airspeed behind the propeller.

2. Temperature Probe

Three temperature probes can be connected to the Series 1585 simultaneously. Each probe can be renamed in the software (ESC, Motor, Battery, Ambient, etc.) and configured with its own safety cutoff. Temperature data is also part of the generated log files. The software can be configured to work in Celsius, Fahrenheit, or Kelvin.

3. Optical RPM Probe

The optical RPM probe provides precise RPM measurement and is easy to install. It measures speeds from 10 to 30,000 RPM. However, because of the hardware limit, the electrical RPM probe does not work effectively when the motor is running at low RPM (<500), or when testing a very low KV motor (<700 RPM/Volt).

4. No-solder Board

The no-solder board can save time and improve your work efficiency when testing multiple motors and ESCs. It can be fixed directly on your test stand allowing the installation of various types of ESCs and motors without any soldering. Three lug connectors can accommodate bullet connectors up to 6 mm or bare wires.

5. Series 1520/1580/1585 Enclosure

The enclosure is an important safety feature, as propellers can break during the test. It can also help to avoid operators from getting too close to the spinning propellers. This product has been tested and proved safe for carbon and plastic propellers no larger than 16" (see product specifications for details). The enclosure comes with an extended lower support to center the propeller in the cage.

## Software

Our open-source propulsion testing software is included with all test stands and allows you to control your propulsion system and record data easily.

The test stand can be controlled manually or automatically with Windows, Linux, Mac and Chrome OS. The interface displays sensor information in textual and graphical form, which can be recorded as single data points or continuous data. We provide pre-written test scripts, which you can then edit or you can write your own custom scripts.

Once the data is recorded, you can easily export it to a .CSV file, readable with most spreadsheet softwares. You can set-up your own working units, safety cut-offs and live plots to meet your needs. Your results will provide you with important information about propeller and motor efficiency as well as consumed power.

- Real time graphs
- Manual motor control
- Manual servo control (three channels)
- Calibration wizard
- Safety cutoffs based on any measured data
- CSV export
- Automated test
  - Ramps
  - Steps
  - Measure Kv
  - Measure number of poles
  - And more...
- User scripts with documentation

